

**SERIES A INTEGRAL POWER SUPPLY**

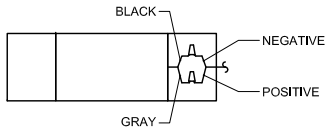

**SERIES A PS01/PS03 POWER SUPPLY**

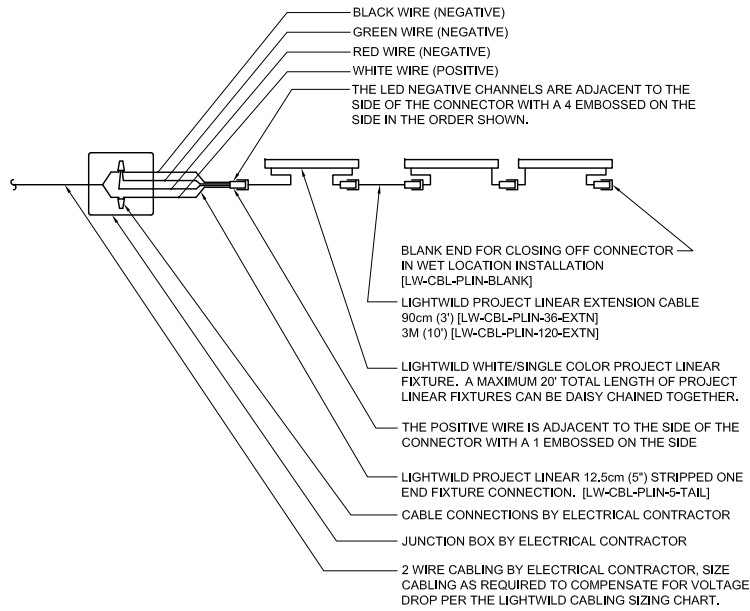

**LIGHTWILD MAXIMUM CABLE LENGTH FOR A SINGLE RUN**

| LOAD AT 24VDC | MAXIMUM CABLE LENGTH TO THE LAST FIXTURE IN A CABLE RUN BY WIRE SIZE |
|---------------|--|
| WATTS         | #18 #16 #14 #12 #10 #8 #6  |
| 0-12          | 0.0-0.5 150 ft 240 ft 300 ft 300 ft 300 ft 300 ft                    |
| 12-24         | 0.5-1.0 75 ft 120 ft 190 ft 300 ft 300 ft 300 ft                     |
| 24-36         | 1.0-1.5 50 ft 80 ft 120 ft 200 ft 300 ft 300 ft                      |
| 36-48         | 1.5-2.0 35 ft 60 ft 95 ft 150 ft 240 ft 300 ft                       |
| 48-60         | 2.0-2.5 N/A 45 ft 75 ft 120 ft 190 ft 300 ft 300 ft                  |
| 60-72         | 2.5-3.0 N/A 40 ft 60 ft 100 ft 160 ft 250 ft 300 ft                  |
| 72-84         | 3.0-3.5 N/A 30 ft 55 ft 85 ft 130 ft 220 ft 300 ft                   |
| 84-90*        | 3.5-4.0 N/A N/A 45 ft 75 ft 120 ft 190 ft 300 ft                     |

\*90 WATTS IS THE MAX WATTAGE PER RUN FOR CLASS 2 INSTALLATIONS

Mounting clips are provided in the following quantities based on fixture length.

| LENGTH                    | QTY |
|---------------------------|-----|
| 6" (152mm)-24" (610mm)    | 2   |
| 26" (660mm)-48" (1219mm)  | 3   |
| 50" (1270mm)-72" (1829mm) | 4   |
| 74" (1880mm)-96" (2438mm) | 5   |

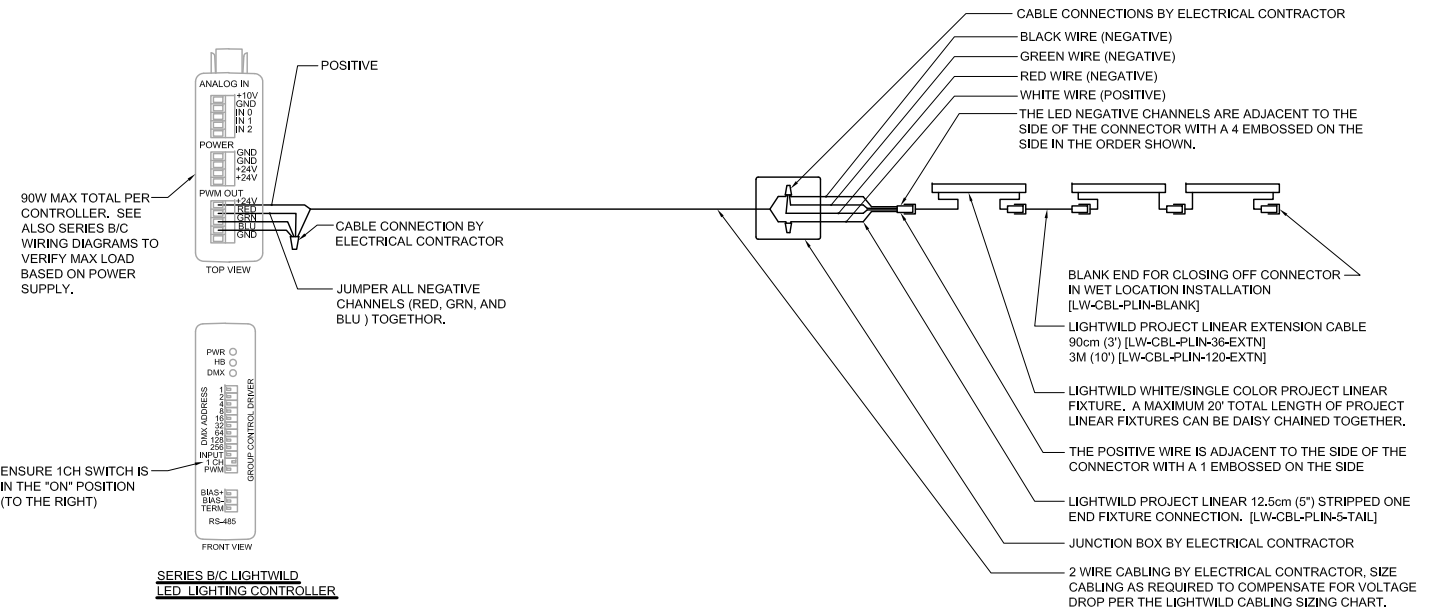

**LEGEND**

- PREINSTALLED
- FIELD INSTALLED
- - - PREINSTALLED OPTION
- - - - FIELD INSTALLED OPTION

WIRING DIAGRAMS ARE GENERIC FOR MULTIPLE PART NUMBERS. EQUIPMENT AND OPTIONS SHOWN ON THE DIAGRAM MAY NOT BE INCLUDED AS PART OF THE EQUIPMENT PROVIDED.

FIXTURES ARE SUBJECT TO CHANGE WITHOUT NOTICE.

LIGHTWILD IS THE OWNER OF ALL COPYRIGHT AND ALL OTHER INTELLECTUAL PROPERTY RIGHTS IN THIS DRAWING AND SHALL ONLY BE USED FOR PURPOSES SET OUT AND APPROVED BY LIGHTWILD. ANY ATTEMPT TO COPY OR DISTRIBUTE THIS DOCUMENT, IN WHOLE OR IN PART, OR TO USE THIS DOCUMENT WITHOUT THE EXPRESS WRITTEN APPROVAL OF LIGHTWILD IS PROHIBITED. COPYRIGHT © 2008 LIGHTWILD

**LIGHTWILD**

7320 W 162ND ST.  
OVERLAND PARK, KS 66085  
913-851-3000

**PART NUMBERS**

LW-PLIN-WW/CW/R/G/B/A-XX

**WIRING DIAGRAM**

PROJECT LINEAR

WHITE/SINGLE COLOR

REV: 04 DATE: 07/13/2010

SCALE: NONE SHEET: 1 OF 1